

Summary of High Energy Particle Detector Elements

Contents

Abstract.....	1
Photomultipliers vs. Photodiodes.....	2
Photomultiplier tube.....	2
Photodiodes.....	3
Preamplifier.....	4
Amplifier.....	5
Multi-Channel Analyser (MCA).....	8
Summary of Detector Specifications.....	10
• Detector response.....	10
• Preamp sensitivity.....	10
• Pulse risetime.....	10
• Peaking time.....	10
• Shaping time.....	10
• FWHM(Γ).....	11
• Energy Resolution:.....	11
• Detector efficiency.....	11
• Dead time:.....	11
• Pulse pile-up:.....	11
• Conversion gain:.....	11
• Series and parallel noise.....	12
• Fano factor (F).....	12
• Differentiator circuit.....	12
• Integrator circuit.....	13
• Single Channel Analyser:.....	13

Abstract

The following document aims to familiarize the reader with detector elements that follow a detector's active volume. It also tries to incorporate different detector specifications and definition of related terminology.

Photomultipliers vs. Photodiodes

Photomultiplier tube

It is a device that detects scintillations given out by the detector material and generates corresponding output pulses. It is essentially like a fast amplifier, which in a few nanoseconds amplifies an incident pulse of visible light by a factor of 10^6 or more.

A photomultiplier consists of two parts:

- Photocathode
 - A photosensitive layer coupled with the detector which absorbs the scintillations produced and generates a flow of electrons (photoelectric effect)
 - Incident photons transfer their energy to electrons, which migrate to the surface and have to overcome the potential barrier (work function) to escape
 - Quantum Efficiency (QE) = no of photoelectrons emitted / no of incident photons. QE is a function of the wavelength of incident photons. Hence the photocathode chosen has the highest QE over the wavelength range of the scintillations produced in the detector. The average QE is around 20-30%
- Electron Multiplier Structure
 - A long tube-like structure that is an efficient collector geometry for photoelectrons. Serves as a near ideal linear amplifier as the output pulse at the anode is proportional to the number of photoelectrons over a large amplitude
 - Photoelectrons generated at the photocathode are made to accelerate and strike the surface of an electrode (called a dynode) kept at a high positive potential and cause a re-emission of more electrons from its surface. A series of such dynodes are arranged at increasing potentials, generating more electrons at each stage
 - The signal is thus amplified to around $10^7 - 10^{10}$ electrons at the anode (output stage)

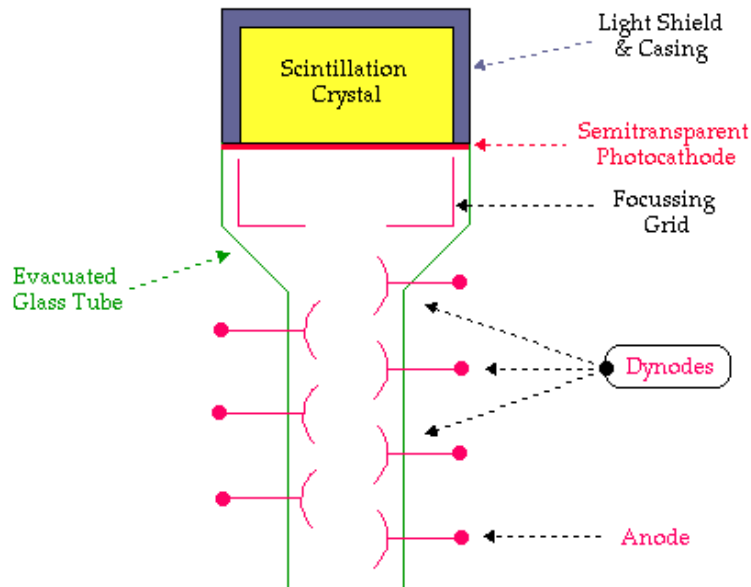

Photodiodes

Photodiodes are solid state devices that generate a current flow when light of suitable wavelength falls on them. When operated in reverse bias, the width of the depletion region (also called the intrinsic or i-region since it has no impurity atoms) at the p-n junction increases and this is where energy from the incoming scintillation is absorbed to generate electron hole pairs.

- The band gap in semiconductors is around 1-2 eV. Photons from the scintillations carrying 3-4 eV pass through the thin p-layer and create electron-hole pairs in the i-region
- These charge carriers are immediately swept away to opposite ends of the diode by the applied external field before they can recombine. This is detected as the output current pulse whose magnitude is proportional to the incident energy of the scintillation
- The quantum efficiency is around 60-80% (much higher than photocathodes) since charge carriers are directly generated by the light pulse. Also this high QE spans a larger range of wavelengths
- Other advantages of using photodiodes are good energy resolution, lower power consumption, compact size and insensitivity to magnetic fields
- One disadvantage is that no amplification of the induced charge in the i-region occurs (as in a PMT) before reaching the preamplifier so the output signal is smaller by orders of magnitude and is affected to a considerable extent by electronic noise
- Another source of noise is dark current which increases with temperature. Thus photodiodes need to be maintained within a certain range of temperature using cooling mechanisms to prevent distortion of the pulse

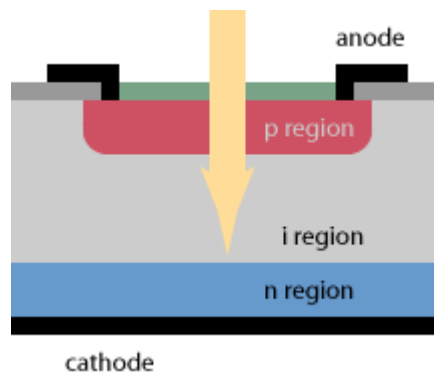

Preamplifier

- Couples the detector with the rest of the circuit electronics
- Provides impedance matching with the rest of the circuit to prevent attenuation of the signal
- Converts the charge collected at the detector to a corresponding output voltage pulse
- Designed to minimise any noise that may be generated. One way is by placing it as close as possible to the detector to reduce cable length
- The preamp output typically has (1) a small amplitude, in the range of a few mV, (2) a fast rise (tens of nsec to μ sec), and (3) following the signal, a slow decay (of the order of 100s of microseconds)
- In some preamps, there is no tail after the signal. A radiation interaction generates a voltage step, and then the output is constant until the next step. When the output level reaches a certain threshold after many such steps, it is reset to its initial value
- For a charge sensitive preamplifier (CSPA):
 - The charge collected in the detector is converted to a voltage value. The output voltage $V_0 = Q/C_f$, under the condition that $A C_f \gg C_i$, where C_i = input capacitance and C_f = output capacitance
 - Noise generated at this stage is due to the input FET and input capacitance and resistance. It increases with the input capacitance, which is present due to the detector itself and the connecting cable
 - Output pulse of the preamplifier has a fast risetime of a few nanoseconds and a slow exponential decay of ~ 100 microseconds

Typical CSPA Circuit

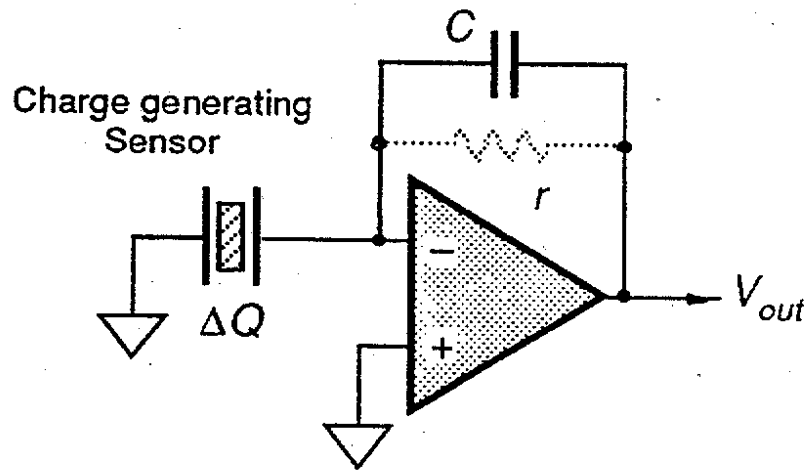

Preamplifier outputs

Preamplifier outputs

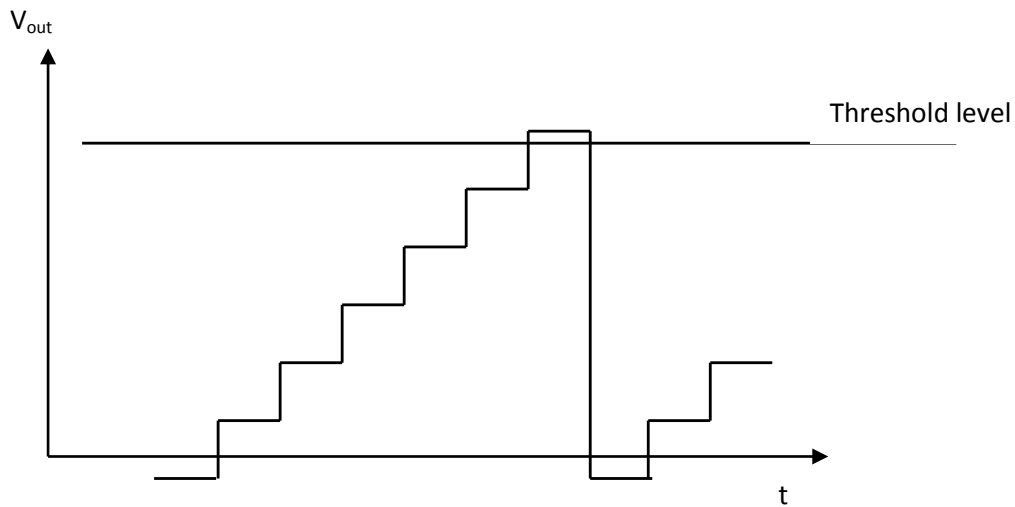

(or)

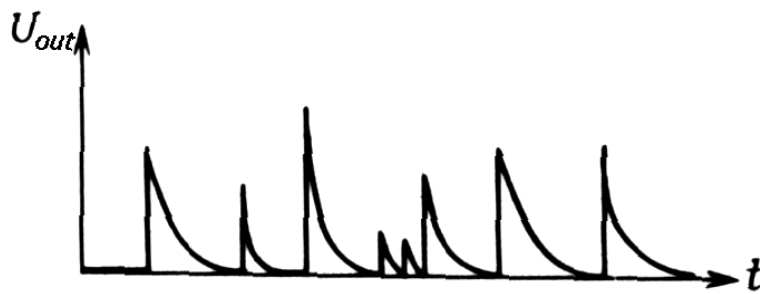

Amplifier

- Amplifies and shapes the preamplifier pulse output
- Uses a combination of differentiator and integrator circuits (CR-RC) to shape the pulse in a manner it can be used for analysis (to study pulse height, risetime etc)
- The different types of shaping include:
 - CR-RC (Unipolar shaping):
 - This is a differentiator circuit followed by an integrator
 - A unity buffer opamp provides impedance isolation between the two circuits
 - The preamp output is shaped into a unipolar pulse, whose shape depends on the time constants of both circuits
 - For a step voltage input of step value E,

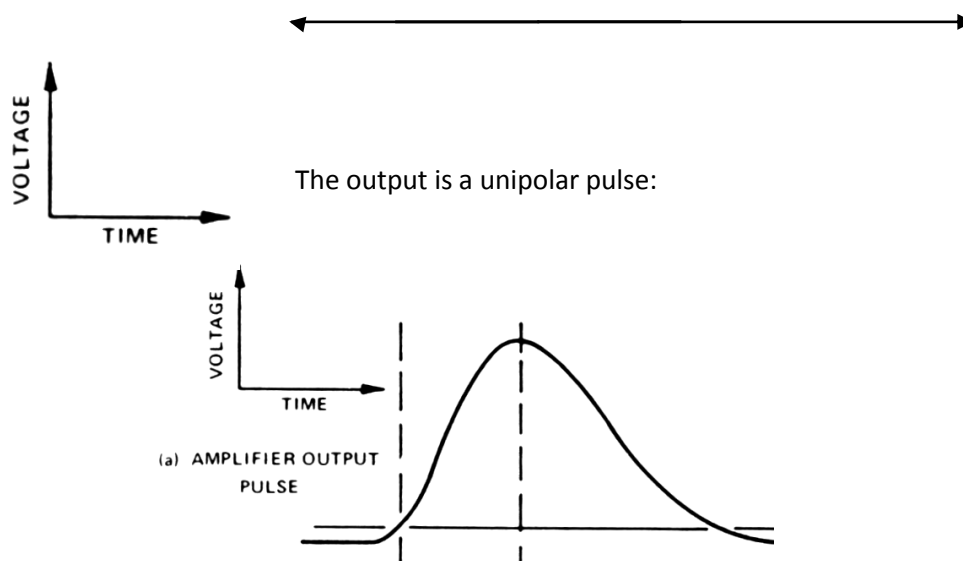

$$\text{with } V_o = (E\tau_1/\tau_1 - \tau_2) * (e^{-t/\tau_1} - e^{-t/\tau_2})$$

CR-RC circuit

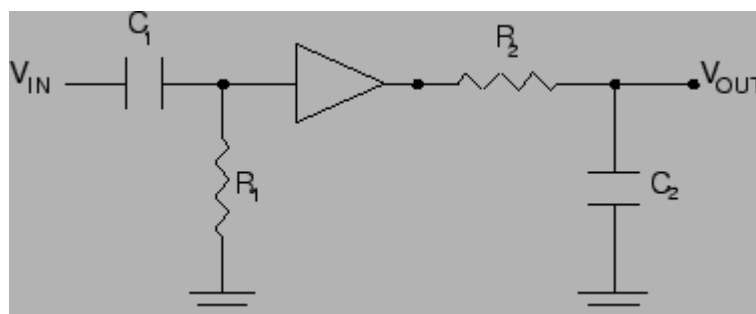

- CR-RC-CR (Bipolar shaping):
 - This is a CR-RC combination followed by a differentiator circuit
 - Unity buffer opamps provide impedance isolation between the three circuits
 - The preamp output is shaped into a bipolar pulse, with two lobes of equal area above and below the zero baseline

- The time taken by the pulse to drop back to the zero level after reaching the peak depends on the risetime of the unshaped pulse, so this method may be used for risetime discrimination
- This shaping is generally used for high counting rate applications, but the S/N ratio is lower than that of a unipolar pulse

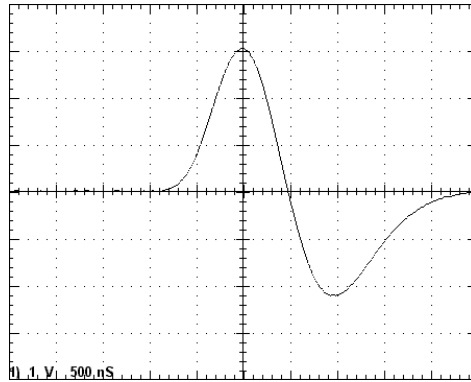

Bipolar pulse

- CR-(RC)ⁿ (Gaussian shaping):
 - This is a differentiator circuit followed by many integrators
 - The pulse shape approaches a Gaussian with increasing number of integrators. In practice, n=4 is sufficient for the difference between the pulse and a true Gaussian to become negligible
 - A Gaussian shaped pulse has better S/N characteristics than a normal unipolar pulse, but greater width of the pulse causes pile-up at higher counting rates
- Shaping of the preamplifier pulse is required to:
 - Optimise S/N ratio. For a specific shape of the pulse, contribution due to series and parallel noise is minimised
 - Prevent pulse pile-up
 - Differentiate between the types of incoming radiation (Pulse Shape discrimination). For certain detector materials the rise/decay time of the pulse varies depending on the incoming radiation
- Ideally should have constant amplification for all pulses. However, this is not so due to
 - Electronic noise generated within the circuit
 - Temperature variations causing small changes in R and C values and transistor functioning
 - Pulse pile-up: depends on counting rate

Multi-Channel Analyser (MCA)

- Is a device that digitises the amplifier output by using an Analog to Digital Converter(ADC)
- The digital memory is divided into a certain number of channels, each of which corresponds to a fixed energy (or voltage) band depending on the maximum recordable voltage (For example, if the maximum pulse height corresponds to 10 V, and the number of channels is 1000, the voltage band of each channel is $10/1000 = .01$ V. So the first channel will store the number of pulses with voltage 0-0.01 V; the second, the number of pulses with voltage 0.01-0.02 V and so on. Larger the channel number, greater the energy it corresponds to)
- When a pulse enters the ADC,
 - 1) An input gate prevents acceptance of another pulse until the current pulse is fully processed and registered
 - 2) A capacitor starts charging and continues until the peak of the pulse is reached
 - 3) Voltage on the charged capacitor is now discharged by a constant dc current
 - 4) An oscillator clock (of a fixed high frequency- a few hundred MHz) starts when the discharging process begins. The clock stops when the capacitor is fully discharged. The number of oscillations produced is proportional to the pulse height, and thus to the incoming voltage (or energy deposited). The time for which the clock runs is called conversion time
 - 5) Depending on the number of oscillations, the pulse is stored in the channel corresponding to that voltage (or energy) band (Memory cycle time)
- An ADC that uses the above method of digitization is called a 'Wilkinson type' ADC. There are other types of ADCs also available
- The final output is a graph of the number of counts recorded in each channel. This graph is called a **pulse height spectrum**

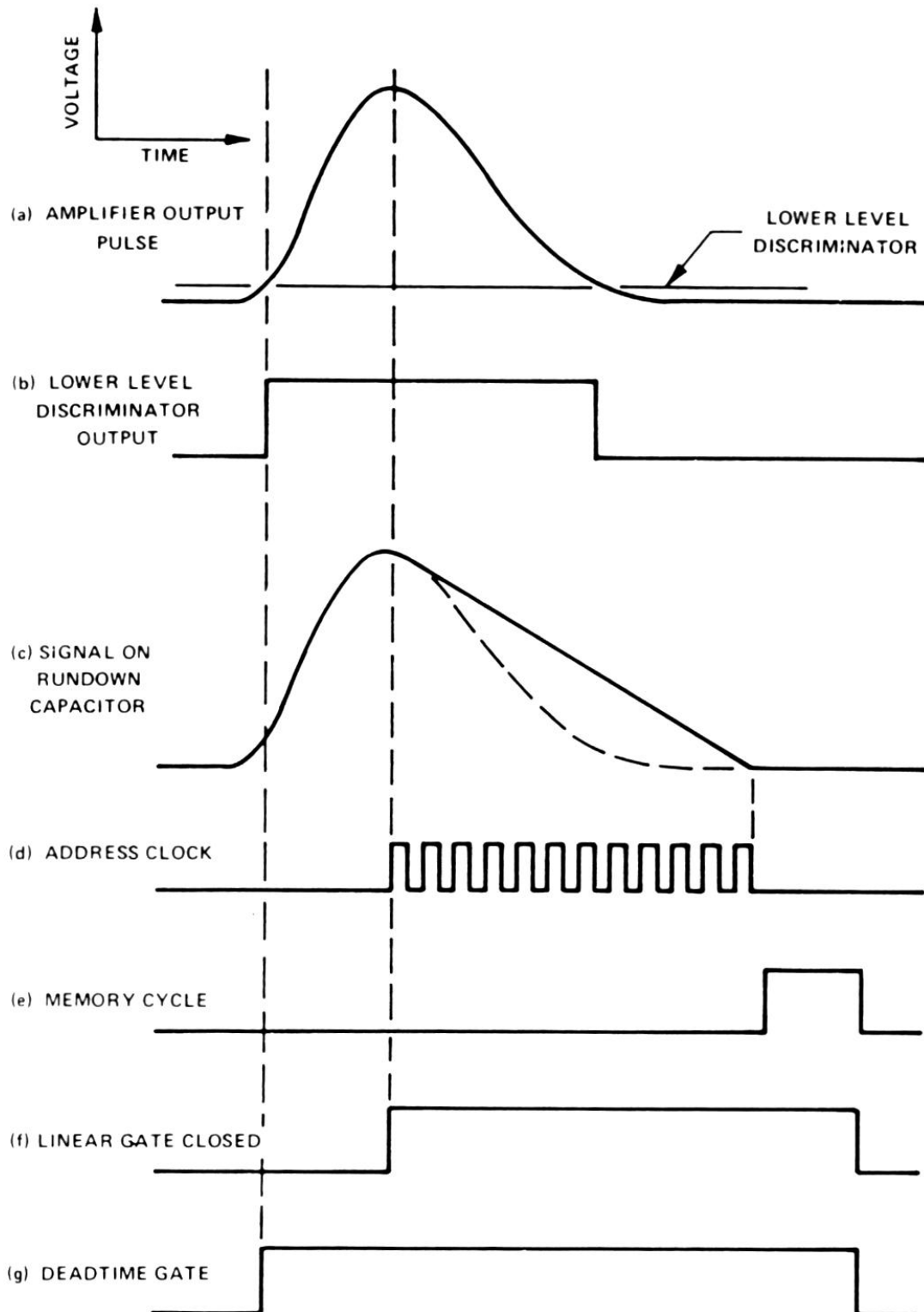

Summary of Detector Specifications

- **Detector response:** The output pulse generated when energy is deposited in the detector. (It is the response of a detector to incident radiation.) It is the redistribution of energy into the voltage (or channel) domain. When monoenergetic radiations strike the detector, only a delta function is expected to be seen in the pulse height spectrum. However the pulse spreads out due to:
 - Statistical nature of interactions of the particles: For example, two particles with the same energy need not deposit equal amount of energy in the detector due to even a slight difference in their path or the way they interact with the material. Spreading due to this factor cannot be prevented

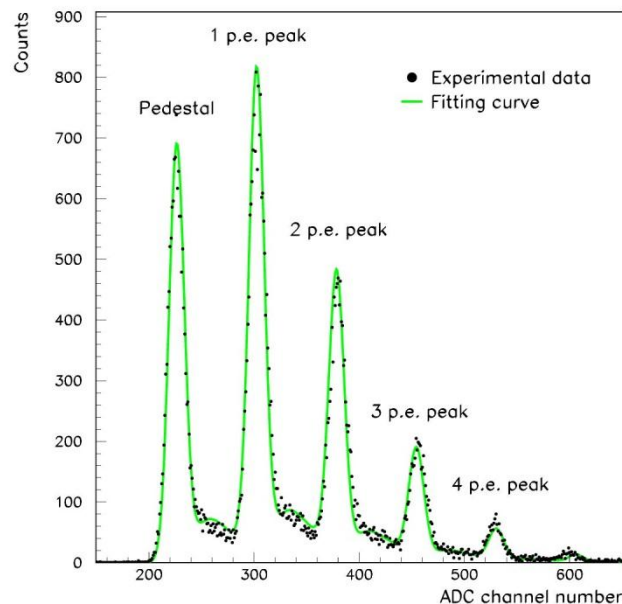

- Electronic noise, which can be minimised by appropriately adjusting circuit parameters
- **Preamp sensitivity** = V/E , or amplitude of voltage generated by a charge sensitive preamplifier per unit energy deposited in the detector
- **Pulse risetime:** Time taken for a pulse to rise from 10-90% of its full amplitude
- **Peaking time:** Time taken for a pulse to go from the zero level to its maximum amplitude
- **Shaping time:** The value of the time constant of each RC circuit in the amplifier

- **FWHM(Γ)**: Full Width at Half Maximum. The width of the response curve at half of its peak value

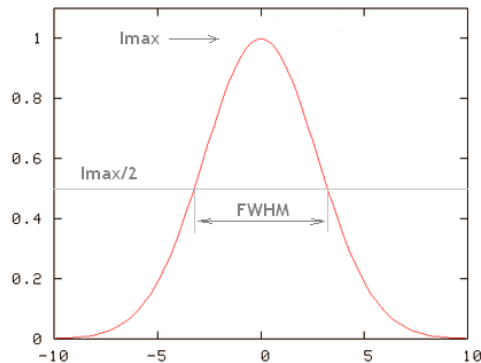

- **Energy Resolution**: For the response curve generated at a particular energy value E_0 , resolution = $(FWHM \text{ at } E_0)/E_0$ and is expressed as a percentage. Lower this value, better the resolution. Assuming Γ remains approximately constant over a small energy range, two energy peaks at E_1 and E_2 can be resolved only if $\Gamma \leq |E_1 - E_2|$
- **Detector efficiency** = number of particles detected per unit time / number of particles impinging upon the detector per unit time. Its value depends on
 - Density and size of detector material
 - Type and energy of radiation
- **Dead time**: The minimum amount of time that must separate two events in order that they be recorded as two separate pulses. It is determined by both the detector itself and associated electronics. Dead time may be decreased by reducing decay time of the voltage pulse, increasing clock speed of the oscillator in the ADC and reducing the conversion gain
- **Pulse pile-up**: The overlap of one signal over another that occurs when a pulse is detected during the processing of the previous pulse, ie, within the dead time. It causes the second pulse to have a higher amplitude and thus gets incorrectly recorded. Decreasing the decay time of a pulse reduces pile-up.

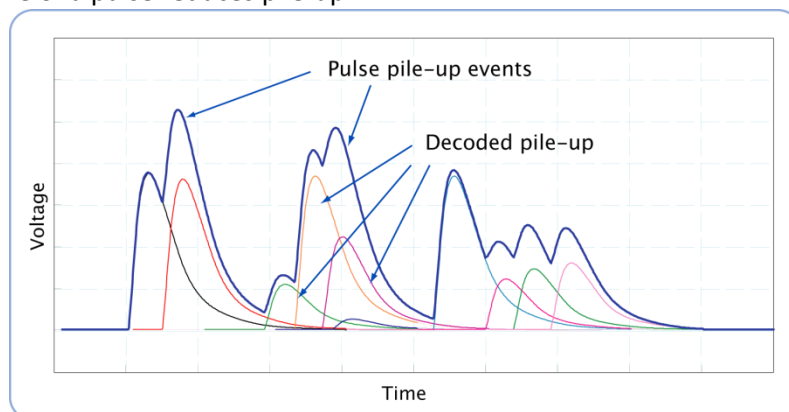

- **Conversion gain**: Number of discrete channels into which the input pulse range is divided in the MCA

- **Series and parallel noise** in PIN detectors
 - Series noise originates from within the preamplifier input stage and increases with detector capacitance. It is also inversely proportional to the shaping time of the pulse
 - Parallel noise occurs due to fluctuations in the leakage current in the photodiode. Leakage current decreases with detector capacitance and is directly proportional to shaping time of the pulse
 - Thus there is an optimum shape of the pulse to minimise the effect of series and parallel noise

- **Fano factor (F)**
 - The number of electron hole pairs generated in a detector = E/w , where E is the average energy deposited and w, the energy required to create an electron hole pair
 - If the process is purely statistical, Poisson distribution applies and the standard deviation (σ) in the number of pairs created is $\sqrt{E/w}$.
 - F is defined as $\sigma^2/\text{no of charge carriers produced}$, or $F = \sigma^2/(E/w)$, or $\sigma = \sqrt{FE/w}$. F is introduced to account for the fact that the standard deviation is lesser than the calculated theoretical value, ie, the process is not purely Poissonian
 - $F = 0$ means that there are no statistical fluctuations and all the energy deposited produces charge carriers
 - $F = 1$ means the number of pairs created is governed by Poisson statistics
 - $0 < F < 1$ means the fluctuations are less than the theoretical value σ , showing that the events recorded are interdependent. Poisson statistics applies to independent events

- **Differentiator circuit**
 - Under the condition that $RC \ll T$ (time period of the pulse), $V_o = RC \cdot dV_i/dt$
 - Acts as a high pass filter, ie, attenuates the low frequency components but high frequency components retain their amplitude
 - When used on a pulse, it causes it to decay faster

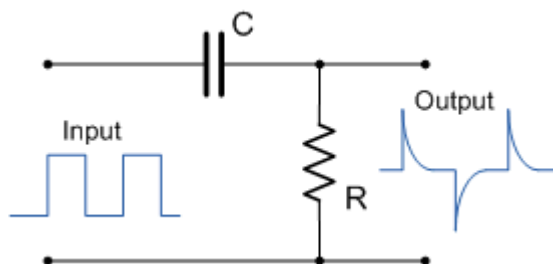

- **Integrator circuit**

- Under the condition that $RC \gg T$ (time period of the pulse), $V_o = (1/RC) \int V_i dt$
- Acts as a low pass filter, ie, attenuates the high frequency components but low frequency components retain their amplitude
- Can be used to decrease the rise time of a pulse, and also smoothen out effects of noise on a pulse

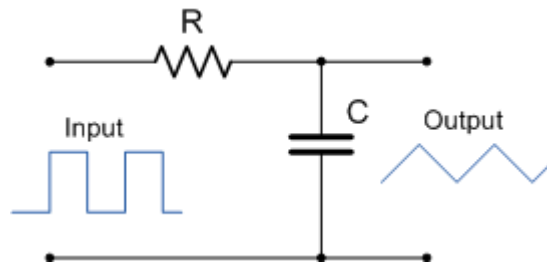

- **Single Channel Analyser:**

- Sets two thresholds, a lower one (called lower level discriminator) and an upper one (called upper level discriminator)
- Counts all pulses whose voltage peaks lie between these threshold values
- A multichannel analyser is like a series of contiguous single channel analysers and counts the peaks in each band